

**SMART & PORTABLE  
TYRE INFLATOR**

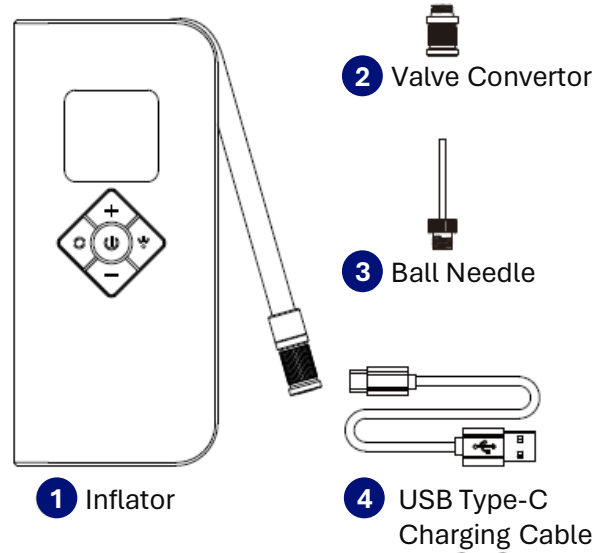

**USER MANUAL  
MODEL A13**





**1. Packing List**

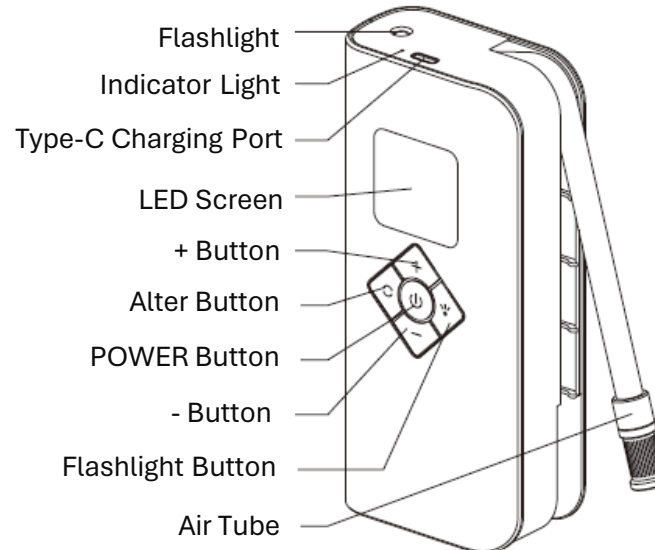

**2. Details**



**3. About Buttons**

	Short Press	Long Press
	Start/Stop Inflating	Turn on/off power
	Turn on/off flashlight (Power On)	Turn on/off flashlight (Power Off)
	Increase pressure	Quick increase
	Reduce pressure	Quick reduce
	Change work mode	Change unit

**4. Operation**

**Start up:** Long press the Power Button until the screen lights up to turn on the power. The screen will display the current pressure.

**Choose Mode:** Press the Alter Button to switch between 4 modes of use; Bicycle, Motorcycle, Car and Basketball. The inflator remembers your previous setting in each mode.



**Set Target Pressure:** Long press the Alter Button to switch the units PSA and BAR. Use the + and - Buttons to adjust the preset air pressure. The screen will flash twice when you stop setting, then it will display the current air pressure.

**Inflation:** Press the Power Button to start inflating. Press again to pause/continue. It will stop automatically when the target pressure is reached.

**Power Off:** Long Press Power Button to turn off or it will shut down automatically after 1 minute of inactivity.

**Flashlight:** Press the Flashlight Button to turn on/off flashlight when the screen is on. Long press the Flashlight Button to turn on/off the flashlight when the screen is off.







## 5. Preset Buttons

Mode	Default Value	Pressure Range	Save the last setting
 Bicycle	45 PSI	3-150 PSI	Yes
 Motorcycle	30 PSI	3-150 PSI	Yes
 Car	35 PSI	3-150 PSI	Yes
 Basketball	8 PSI	3-150 PSI	Yes



Ensure that you set the appropriate target pressure for your specific inflatable. Incorrect pressure settings may cause personal injury, property damage or adversely affect the performance of the inflator.

## 6. Valve Installation

Inflator Interface			
Valve Type	 Schrader Valve	 Presta Valve	 Ball

## 7. Recharging

1. Fully charge the inflator using a Type-C charging cable, especially after long time inactivity.
2. The charging indicator will turn red during the charging and turn green when the battery is fully charged.
3. Recharge the inflator at least once every three months even when not in use to avoid battery damage.

## 8. Precautions

1. The inflator may become hot after working for more than 1 minute. Avoid touching the hot part of the tube.
2. Inspect the inflator before use. Do not use if you find any issues.
3. If abnormal sounds or excessive temperatures occur during inflation, stop using the inflator immediately.
4. Ensure proper airflow during inflation.
5. The inflators compressor may produce electric sparks. Keep it away from flammable or explosive materials.
6. Stay in the area while it is in operation to avoid accidents.
7. After extended use, the inflator and air tube will become hot. Allow it to cool down before using it again.
8. Prevent exposure to dirt, water and impact damage.
9. Do not use harsh chemicals, cleaning agents or detergents during cleaning.
10. Store the inflator in a temperate, dry environment.
11. Children should not use the inflator. Keep it out of their reach.
12. Do not direct airflow into the mouth, ears, eyes or other sensitive areas of people or animals.
13. Do not use the inflator while it is being charged.

## 9. Specification

Size	160.5x73.5x38.5mm
Weight	410g
Working Voltage/Current	7.4V 1-6A
Battery	2000mAh 7.4V 14.8Wh
Charging mode	Type-C
Charging time	2 hours
Maximum inflating pressure	150 PSI & 10.3 BAR
Operation Temperature	-10°C ~ +60°C



Made in China